

# AIR.55

## Pneumatic drilling machine

**EUROBOOR**

FOR PROFESSIONALS BY PROFESSIONALS

### Technical data

	Metric	Imperial
Annular cutting	Ø 12 - 52 mm (HSS)	Ø 7/16" - 2 1/16" (HSS)
	Ø 12 - 55 mm (TCT)	Ø 7/16" - 2 3/16" (TCT)
Twist drilling	Ø 1 - 23 mm	Ø 1/16" - 15/16"
Countersinking	Ø 10 - 55 mm	Ø 7/16" - 2 3/16"
Length	380 mm	14 15/16"
Width	245 mm	9 5/8"
Height	615 - 705 mm	24 3/16" - 27 3/4"
Stroke	167 mm	6 9/16"
Weight*	16.5 kg	36.4 lbs
Magnet	183 x 100 x 55 mm	7 3/16" x 3 15/16" x 2 3/16"
Magnetic force	900 kg	1,984 lbs
Speed (no load)		380 rpm
Spindle (Weldon)	MT3 19.05 mm	MT3 3/4"
Power source	Air, min. 6.3 bar, max. 8 bar, consumption 1.1 m³/min	

\* Without handles

### Features



Air motor:  
min 6.3 bar  
(90 PSI)



Atex

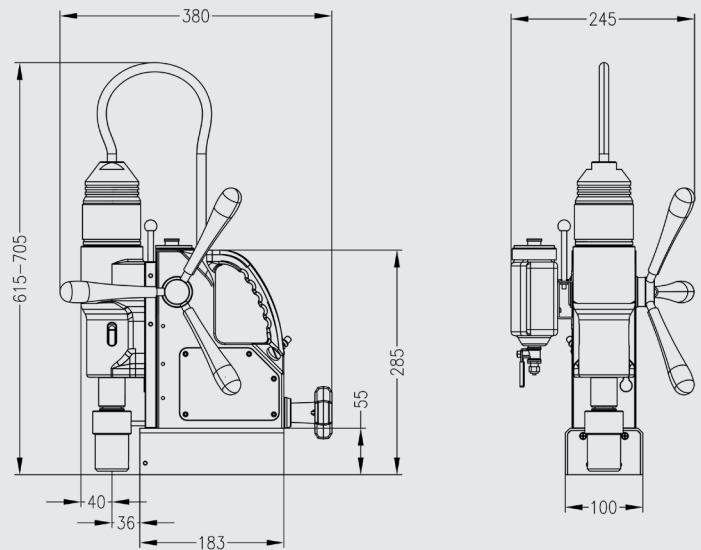

Euroboor makes every effort to meet quality and integrity requirements. That is why we as an organization are proud of the recognition of some leading organizations worldwide:



[www.euroboor.com](http://www.euroboor.com)