

ECO.32

Magnetic drilling machine

EUROBOOR

FOR PROFESSIONALS BY PROFESSIONALS

Technical data

	Metric	Imperial
Annular cutting	Ø 12 - 32 mm	Ø 1/2" - 1 1/4"
Twist drilling	Ø 1 - 13 mm	Ø 1/16" - 1/2"
Countersinking	Ø 10 - 40 mm	Ø 3/8" - 1 9/16"
Length	320 mm	12 5/8"
Width	210 mm	8 1/4"
Height	370 - 512 mm	14 9/16" - 20 3/16"
Stroke	150 mm	5 15/16"
Weight*	11 kg	24.3 lbs
Magnet (l x w x h)	160 x 80 x 42 mm	6 5/16" x 3 1/8" x 1 5/8"
Magnetic force	1,500 kg	3,305 lbs
Motor power	1,000 W	9.1 A
Total power	1,050 W	9.5 A
Speed (no load)		775 rpm
Speed (load 1,000 W, 9.1 A)		440 rpm
Spindle (Weldon)	19.05 mm	3/4"
Voltage		110 - 120 V / 60 Hz 220 - 240 V / 50 - 60 Hz

* Without power cord and handles

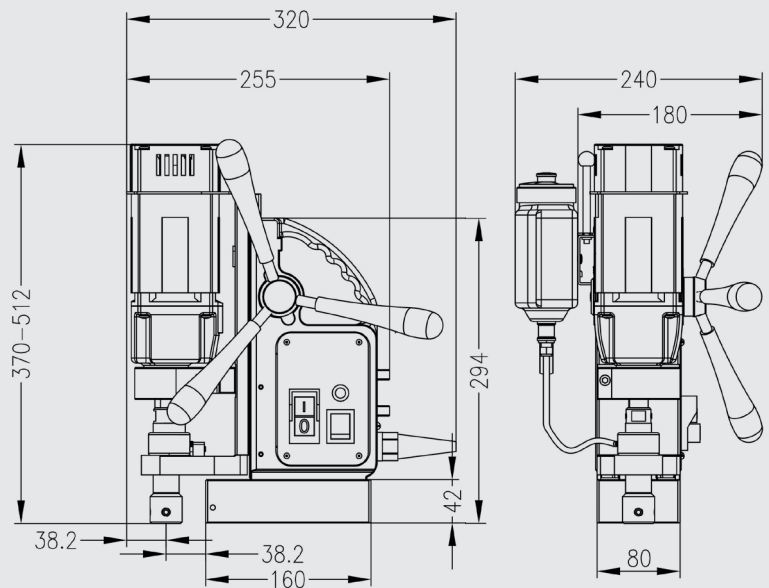

Features



**Magnet
LED-indicator
(SensorTec)**



Euroboor makes every effort to meet quality and integrity requirements. That is why we as an organization are proud of the recognition of some leading organizations worldwide:



www.euroboor.com